

SEARS
SEATING

D5090 VRS

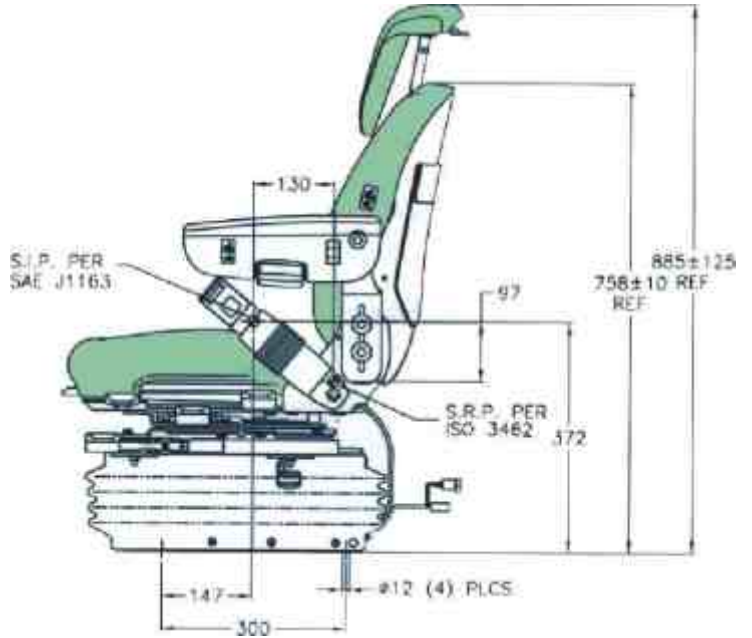

D5090 VRS



Large very low frequency, VRS Computer Controlled, plug & play Active-S air suspension, with three position ride selector & Airide® high volume air spring.

FEATURES

- Deluxe cut & sew seat covers on double depth cushions
- Upper back rest height adjustable
- Back angle fully adjustable
- Automatic ride protection system (ARPS™)
- Height adjustment 76mm
- Automatic height & weight adjustment 50 -150kg
- Horizontal isolator fully integrated, sprung & Duo® Damped
- Lateral isolator slide type, sprung and damped
- Motion Master® Semi-Active Damper
- Ride selector 3 three positions
- Armrests with height pitch & tilt up adjustment
- Suspension stroke 90mm
- Swivel 21°- 21°
- Electric air lumbar
- Operator presence switch
- Moulded suspension cover
- External air tank for optimum ride volume
- Vibration performance to ISO 7096

OPTIONS

- Seat belt to ISO 6683
- Seat heaters 12, 24, 48v
- Luxury Leather trim
- Range of fabric, velour or PVC trim

Sears Manufacturing Co.)Europe(Ltd
Unit 33, Rassau Industrial Estate,
Ebbw Vale, Gwent NP23 5SD.
United Kingdom
Tel. 0044)0(1495 304518
Fax. 0044)0(1495 304452
Email: info@searsseating.co.uk
www.searsseating.com

		VRS,	Active-S
"	"		
		Airide®.	
			(ARPS™)
		50-150 kg	
Duo®			
		Motion Master®	
		90mm	
		21° - 21°	
			ISO 7096
			ISO 6683
		12, 24, 48v	

